



Model number

INY030D-F99-B16-V15

Features

- E1-Type approval
- High shock resistance
- Extended temperature range -40 ... +85 °C
- CANopen interface
- Measuring range -15° ... +15°
- Increased noise immunity 100 V/m

Electrical connection

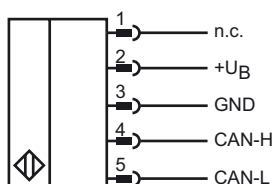

Technical Data

General specifications

Type	Inclination sensor, 2-axis
Measurement range	-15 ... 15 °
Absolute accuracy	≤ ± 0.2 °
Response delay	≤ 25 ms
Resolution	≤ 0.01 °
Repeat accuracy	≤ ± 0.02 °
Temperature influence	≤ 0.004 °/K

Functional safety related parameters

MTTF _d	300 a
Mission Time (T _M)	20 a
Diagnostic Coverage (DC)	0 %

Indicators/operating means

Operation indicator	LED, green
---------------------	------------

Electrical specifications

Operating voltage U _B	10 ... 30 V DC
No-load supply current I ₀	≤ 50 mA
Time delay before availability t _v	≤ 2.5 s

Interface

Interface type	CANopen
Device profile	CiA410, Ver. 1.2
Data output code	binary code
Transfer rate	10 ... 1000 kBit/s , programmable
Node ID	1 ... 127 , programmable
Termination	external
Cycle time	≥ 20 ms

Ambient conditions

Ambient temperature	-40 ... 85 °C (-40 ... 185 °F)
Storage temperature	-40 ... 85 °C (-40 ... 185 °F)

Mechanical specifications

Connection type	5-pin, M12 x 1 connector
Housing material	PA
Degree of protection	IP68 / IP69K
Mass	240 g

Factory settings

Node ID	1
Transfer rate	250 kBit/s

Compliance with standards and directives

Standard conformity	
Shock and impact resistance	100 g according to DIN EN 60068-2-27
Standards	EN 60947-5-2:2007 IEC 60947-5-2:2007

Approvals and certificates

UL approval	cULus Listed, Class 2 Power Source
CSA approval	cCSAus Listed, General Purpose, Class 2 Power Source
E1 Type approval	10R-04

EMC Properties

Interference immunity in accordance with
DIN ISO 11452-2: 100 V/m

Frequency band 20 MHz up to 2 GHz

Mains-borne interference in accordance with ISO 7637-2:

	1	2a	2b	3a	3b	4
Severity level	III	III	III	III	III	III
Failure criterion	C	A	C	A	A	C

EN 61000-4-2: CD: 8 kV / AD: 15 kV

Severity level IV IV

EN 61000-4-3: 30 V/m (80...2500 MHz)

Severity level IV

EN 61000-4-4: 2 kV

Severity level III

EN 61000-4-6: 10 V (0.01...80 MHz)

Severity level III

EN 55011: Klasse A

Dimensions

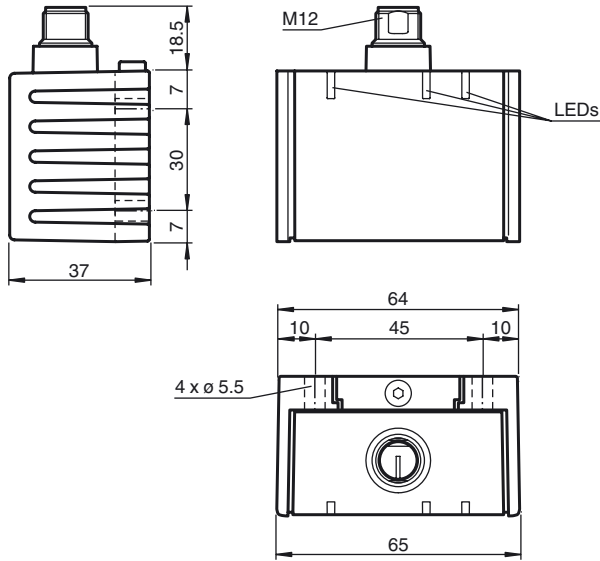

Sensor Orientation

In the default setting the zero position of the sensor is reached, when the sensor is mounted on a horizontal plane and electrical connection faces sideways.

Mounting of the sensor

Sensors from the -F99 series consist of a sensor module and accompanying cast aluminum housing. Select a horizontal flat surface with minimum dimensions of 70 mm x 50 mm to mount the sensor. Mount the sensor as follows:



1. Loosen the central screw under the sensor connection.
 2. Slide back the clamping element until you are able to remove the sensor module from the housing.
 3. Remove the sensor module from the housing
 4. Position the housing at the required mounting location and secure using four countersunk screws. Make sure that the heads of the screws do not protrude.
 5. Place the sensor module in the housing.
 6. Slide the clamping element flush into the housing. Check that the sensor element is seated correctly.
 7. Finally tighten the central screw.
- The sensor is now mounted correctly.

Baud rate setting

Inclination sensors by Pepperl+Fuchs are supplied with a baud rate of 250 kbit/s. To change the baud rate, write the new baud rate to object 2001h "Baud rate." If a "Reset sensor" command is issued via an NMT message or the power supply is interrupted, the sensor operates at the new baud rate. Invalid values are not adopted. In this case, the current setting is retained.

Example of modifying the baud rate from 250 kbit/s to 1 Mbit/s:

601h	2Fh	01h	20h	00h	08h	xxh	xxh	xxh
CAN-ID	Com-mand	Object index	Subindex	New baud rate	not used			
	Data byte 1	Data byte 2	Data byte 3	Data byte 4	Data byte 5	Data byte 6	Data byte 7	Data byte 8

CAN ID: 601h, SDO1 channel of node 1

Command: 2Fh, write object, 1 byte of usable data

Object index: 2001h, note: low byte first, then high byte!

Subindex: 00h

New baud rate: 08h, for 1 Mbit/s

New baud rate: 07h, for 800 kbit/s

Pinout

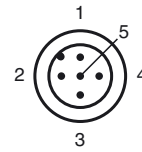

Wire colors in accordance with EN 60947-5-2

- | | | |
|---|----|---------|
| 1 | BN | (brown) |
| 2 | WH | (white) |
| 3 | BU | (blue) |
| 4 | BK | (black) |
| 5 | GY | (gray) |

Accessories

V15-G-2M-PUR-CAN-V15-G

DeviceNet/CANOpen bus cable, M12 to M12, PUR cable 5-pin

V15-G-5M-PUR-CAN-V15-G

DeviceNet/CANOpen bus cable, M12 to M12, PUR cable 5-pin

V15-G-10M-PUR-CAN-V15-G

DeviceNet/CANOpen bus cable, M12 to M12, PUR cable 5-pin

V15S-T-CAN/DN-V15

Y distributor, M12 socket on M12 connector/socket

ICZ-TR-CAN/DN-V15

Terminal resistor for DeviceNet, CANOpen

New baud rate: 06h, for 500 kbit/s
New baud rate: 05h, for 250 kbit/s
New baud rate: 04h, for 125 kbit/s
New baud rate: 03h, for 100 kbit/s
New baud rate: 02h, for 50 kbit/s
New baud rate: 01h, for 20 kbit/s
New baud rate: 00h, for 10 kbit/s

LED displays

The inclination sensor has three indicator LEDs that allow rapid visual monitoring.

- The green **power** LED indicates the state of the power supply
- The yellow **run** LED indicates the bus and sensor status
- The red **err** LED indicates an error

power (green)	run (yellow)	err (red)	Meaning
Off	Off	Off	No power supply
On	Flashing constantly	Off	Pre-operational
On	1x flashing	Off	Stopped
On	On	Off	Operational
On	Off	On	CAN bus off
On	depending on bus status	1x flashing	Warning, e.g., outside measuring range
On	depending on bus status	2x flashing	Error, e.g., EEPROM checksum incorrect
Flashing constantly	Off	On	Undervoltage